

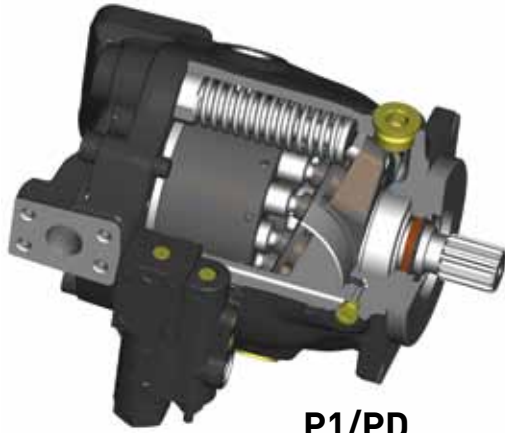

Piston Pumps (Mobile or Industrial)

P1/PD Medium Pressure Mobile Piston Pumps



Benefits/Features

- Compact overall package size
- Quiet operation
- Low flow ripple to further reduce noise
- Elastomer seals that eliminate gaskets and external leakage
- High operating efficiency for lower power consumption and reduced heat generation
- Simple hydraulic controls with “no-leak” adjustments
- SAE and ISO standard mounting flanges and ports
- Long life, tapered-roller shaft bearings
- Long life, low friction, hydrostatically balanced cam bearings
- Full power through-drive capability
- End or side inlet and outlet ports
- Case drain ports for horizontal or vertical, shaft-up mounting
- Optional minimum and maximum displacement adjustments
- Optional case-to-inlet check valve to extend shaft seal life
- Easy to service

P1/PD Medium Pressure Mobile Piston Pumps

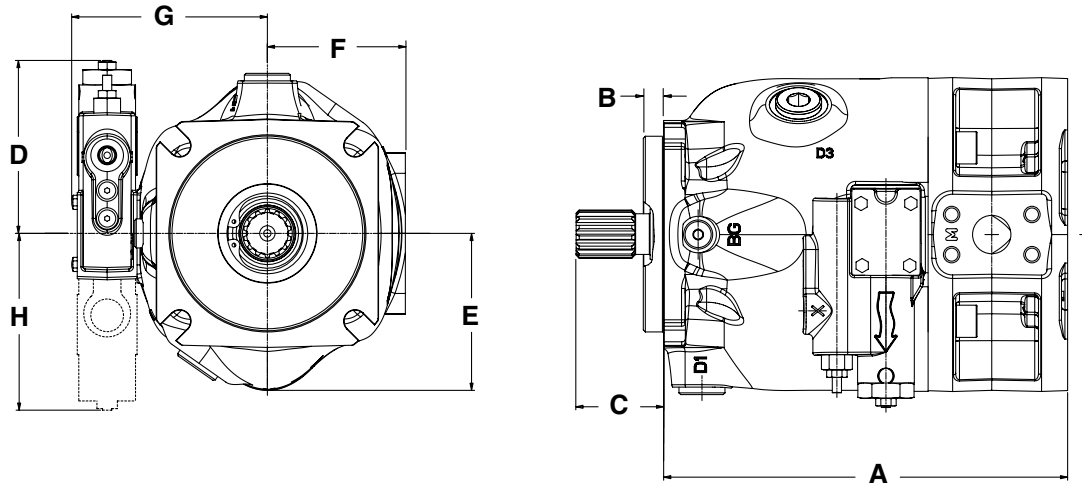

Dimensions, inch (mm)

Series	A	B	C Max.	D	E	F	G	H Max.
P1/PD018	6.46 (164.2)	0.24 (6.2)	1.29 (32.8)	4.72 (120)	2.97 (75.5)	2.60 (66)	4.24 (107.7)	4.80 (122)
P1/PD028	9.25 (235.5)	0.37 (9.5)	1.84 (46.8)	4.72 (120)	3.21 (81.5)	2.93 (74.5)	4.48 (113.8)	4.80 (122)
P1/PD045	9.00 (228.7)	0.37 (9.5)	1.84 (46.8)	4.72 (120)	3.63 (92.3)	2.92 (74.2)	4.75 (120.7)	4.80 (122)
P1/PD060	9.96 (253.0)	0.50 (12.7)	2.24 (56.8)	4.72 (120)	3.98 (101.2)	3.23 (82)	4.88 (123.9)	4.80 (122)
P1/PD075	10.37 (263.5)	0.50 (12.7)	2.24 (56.8)	4.72 (120)	4.09 (103.8)	3.54 (90)	5.03 (127.7)	4.80 (122)
P1/PD100	13.37 (339.6)	0.50 (12.7)	2.47 (62.8)	4.72 (120)	4.61 (117.1)	3.98 (101)	5.66 (143.7)	4.80 (122)
P1/PD140	14.34 (364.3)	0.50 (12.7)	2.97 (75.5)	4.72 (120)	5.24 (133)	4.45 (113)	6.13 (155.7)	4.80 (122)

SAE Flanges & Shafts

	PD018	PD028, PD045	PD060, PD075	PD100	PD140
Mounting flange, SAE	82-2 (A)	101-2 (B)	127-4 (C)	127-4 (C)	152-4 (D)
Pilot diameter, in (mm)	3.2 (82.5)	4.0 (101.6)	5.0 (127)	5.0 (127)	6.0 (152.4)
Keyed shaft, SAE	19-1 (A)	25-1 (B-B)	32-1 (C)	38-1 (C-C)	44-1 (D)
Spline shaft, SAE	11T-16/32P	15T-16/32P (B-B)	14T-12/24P (C)	17T-12/24P (C-C)	13T-8/16P (D)

Piston Pumps

P1/PD 28cc, Model Ordering Code

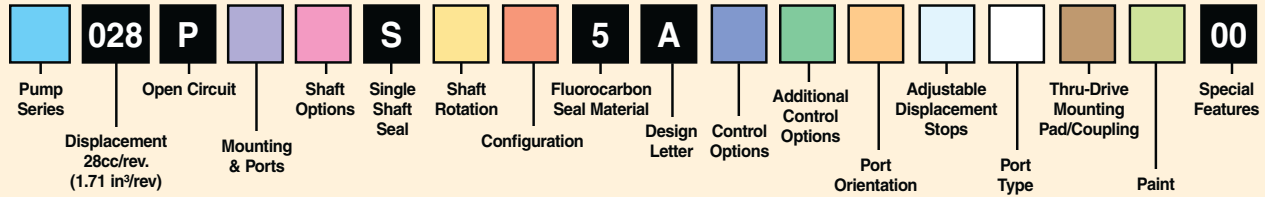

Pump Series	
P1	Mobile
PD	Industrial

Mounting & Ports	
S	SAE B Pilot SAE Work Ports with SAE Aux Ports
A	SAE B Pilot Metric Work Ports with BSPP Aux Ports
M	ISO - 100MM Pilot Metric Work Ports with Aux Ports
B	ISO - 100MM Pilot Metric Work Ports with BSPP Aux Ports

Shaft Options	
01	Splined shaft - SAE B-B 15T
02	Keyed shaft - SAE B-B 1" Dia.
04	ISO keyed 25MM Dia.
08	Splined shaft - SAE B 13T

Shaft Rotation	
R	Clockwise
L	Counterclockwise

Configuration	
M	Mobile (P1)
S	Industrial (PD)

Control Options	
C0	Pressure limiter 1160.30 - 4061.05 PSI (80 - 280 bar)
C1	Pressure limiter 290.08 - 1160.30 PSI (20 - 80 bar)
L0	Load sensing 145.04-435.11 PSI ΔP (10-30 bar ΔP) with pressure limiter 1160.30 - 4061.05 PSI (80 - 280 bar)
L2	Load sensing 145.04-435.11 PSI ΔP (10-30 bar ΔP) with bleed & pressure limiter 1160.30 - 4061.05 PSI (80 - 280 bar)
AN*	Pilot operated pressure limiter with ISO4401 interface & SAE 4 Vent Port
AM	Pilot operated pressure limiter with mechanical adjustment and SAE 4 Vent Port
AE	Pilot operated pressure limiter with mechanical and electrical adjustment 12 VDC
AF	Pilot operated pressure limiter with mechanical and electrical adjustment 24 VDC
##	See chart below for electronic control options

*Not functional control as such

Additional Control Options	
0	No other options
2	Displacement sensor **

** mandatory with "W***", "X***", "Y***", "Z***" "D*" and "Y*"

Port Orientation	
E	End Ports
R	Side ported with ripple chamber
T	Side ported with through drive

Adjustable Displacement Stops* (For E & R Port Orientation Only)	
0	None
1	Adjustable maximum displacement stop
2	Adjustable minimum displacement stop
3	Adjustable maximum and minimum displacement stop

*Not available with Thru-Drive

Port Type	
0	Flange Ports
2	Threaded Ports

Thru-Drive Mounting Pad/Coupling	
0	No Thru-Drive
A	SAE 82-2 (A), 16 (A), 9T coupling
H	SAE 82-2 (A), 19 (-), 11T coupling
B	SAE 101-2 (B), 22 (B) , 13T coupling
Q	SAE 101-2 (B), 25 (B-B), 15T coupling

Paint	
00	No Paint
PB	Black Paint

Electronic Control Options	
#	#

0	No ECU
D	Proportional displacement control
Y	Proportional pressure and displacement control

P	Electronic valve with zero displacement default
T	Electronic valve with max displacement default
S	Electronic valve with zero displacement default and hydromechanical Pmax
U	Electronic valve with max displacement default and hydromechanical Pmax
W	Electronic valve with zero displacement default (CANBUS compatible)
X	Electronic valve with max displacement default (CANBUS compatible)
Y	Electronic valve with zero displacement default and hydromechanical Pmax (CANBUS compatible)
Z	Electronic valve with max displacement default and hydromechanical Pmax (CANBUS compatible)

*** W, X, Y and Z only available with "D*" and "Y*"