

OAW Water Oil Cooler

For mobile and industrial use



The OAW oil cooler is optimized for use in mobile and industrial sectors. Together with a wide range of accessories, the OAW cooler is suitable for installation in most applications and environments.

- **Optimized design and the right choice of materials and components ensure reliable and long-lasting cooling with low service and maintenance costs.**
- **Compact design for easy installation.**
- **Turbulent water flow prevents clogging and reduces maintenance.**
- **Low water consumption for economical operation.**
- **SAE O-ring connections for ease of assembly and leak-proof operation.**
- **Maximum material efficiency with no “Dead Zone.”**

General

Our OAW coolers are designed for a maximum working pressure of 450 psi. The most standard application for the OAW cooler involves a cold water circuit and a hot oil circuit. Fluids are not limited to oil and water however; see the Fluid Compatibility section in the OAW product literature for more information. Inlets and outlets are clearly identified by the Accumulator and Cooler Division sticker affixed to the front of the unit. When in doubt, pour a liquid in one of the connections and note which connection it comes out of. This will be the inlet and outlet for one circuit (either oil or water). The other inlet should be located on the diagonal from the first inlet. Maximum cooling efficiency is achieved by cross flowing through the plates, the oil inlet and water inlet being located on a diagonal.

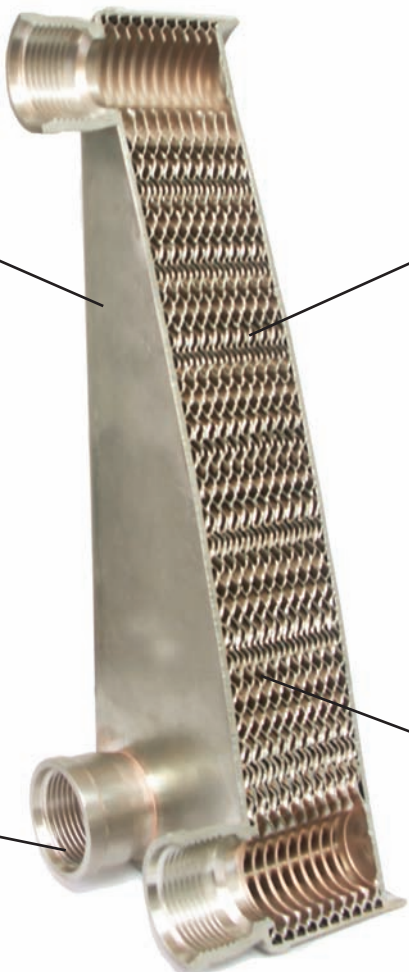

Extremely Compact:
85-90% Reduction in volume and weight of a shell-and-tube heat exchanger of the same capacity.

LOW WATER CONSUMPTION. ECONOMICAL OPERATION COMPACT.

Corrugated:
Plates made of 316 stainless steel brazed with pure copper.

TURBULENT WATER FLOW PREVENTS CLOGGING AND REDUCES MAINTENANCE. SMALLER SIZE MAKES IT EASY TO INSTALL.

BROAD RANGE: SEVERAL MODELS IN-STOCK FOR IMMEDIATE DELIVERY.

SAE O-Ring Connections:
Good for ease of assembly and leak proof operation.

Maximum Efficiency:
Maximum material efficiency. No "Dead Zone" because there is no need for gaskets. Up to 25% more capacity utilization.

OAW 14 & OAW 34

MODEL	Cooling Capacity (*hp)	Connection	A (inches)	Weight (lbs.)	Volume (in ³)
OAW 14-10-SG	2-7	5/8" SAE O-ring	1.4	1.4	15
OAW 34-20	6-33	1" SAE O-ring	2.3	9	74
OAW 34-40	20-69	1" SAE O-ring	4.1	15	149

*Cooling capacity is calculated with the following conditions. For other flow conditions, type of fluids or temperatures, please see page 35 or consult Accumulator and Cooler Division. Oil type – ISO VG 32 – Oil/water flow ratio – 2:1 – Oil inlet temperature – 140°F – Water inlet temperature – 80°F

OAW 14 & 34 COOLING CAPACITY

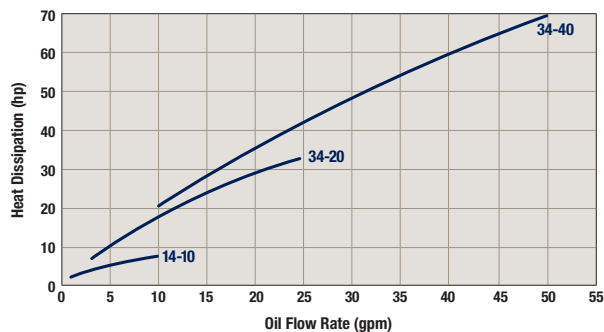

OAW 14 & 34 PRESSURE DROP

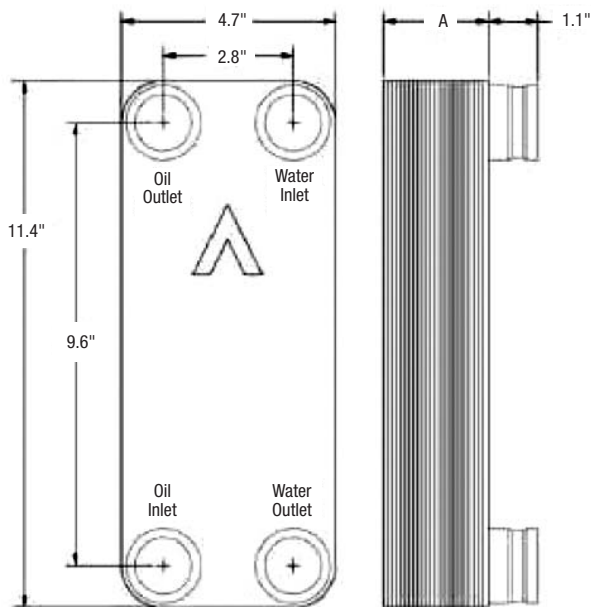
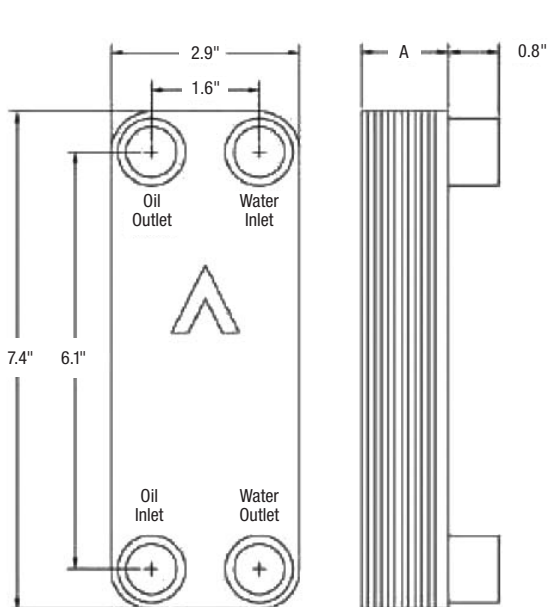
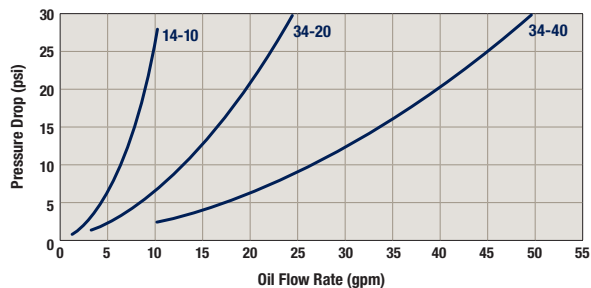

OAW 46 & OAW 61

MODEL	Cooling Capacity (*hp)	Connection	A (inches)	Weight (lbs.)	Volume (in ³)
OAW 46-40	21-94	1¼" SAE O-ring	3.9	13	200
OAW 46-60	23-142	1¼" SAE O-ring	5.7	18	300
OAW 61-40	27-98	1¼" SAE O-ring	3.9	19	271
OAW 61-60	53-152	1¼" SAE O-ring	5.7	27	406
OAW 61-80	79-198	1¼" SAE O-ring	7.4	34	542

*Cooling capacity is calculated with the following conditions. For other flow conditions, type of fluids or temperatures, please see page 35 or consult Accumulator and Cooler Division. Oil type – ISO VG 32 – Oil/water flow ratio – 2:1 – Oil inlet temperature – 140°F – Water inlet temperature – 80°F

OAW 46 & 61 COOLING CAPACITY

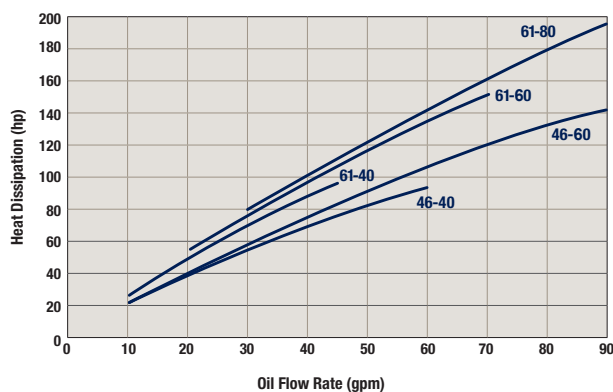

OAW 46 & 61 PRESSURE DROP

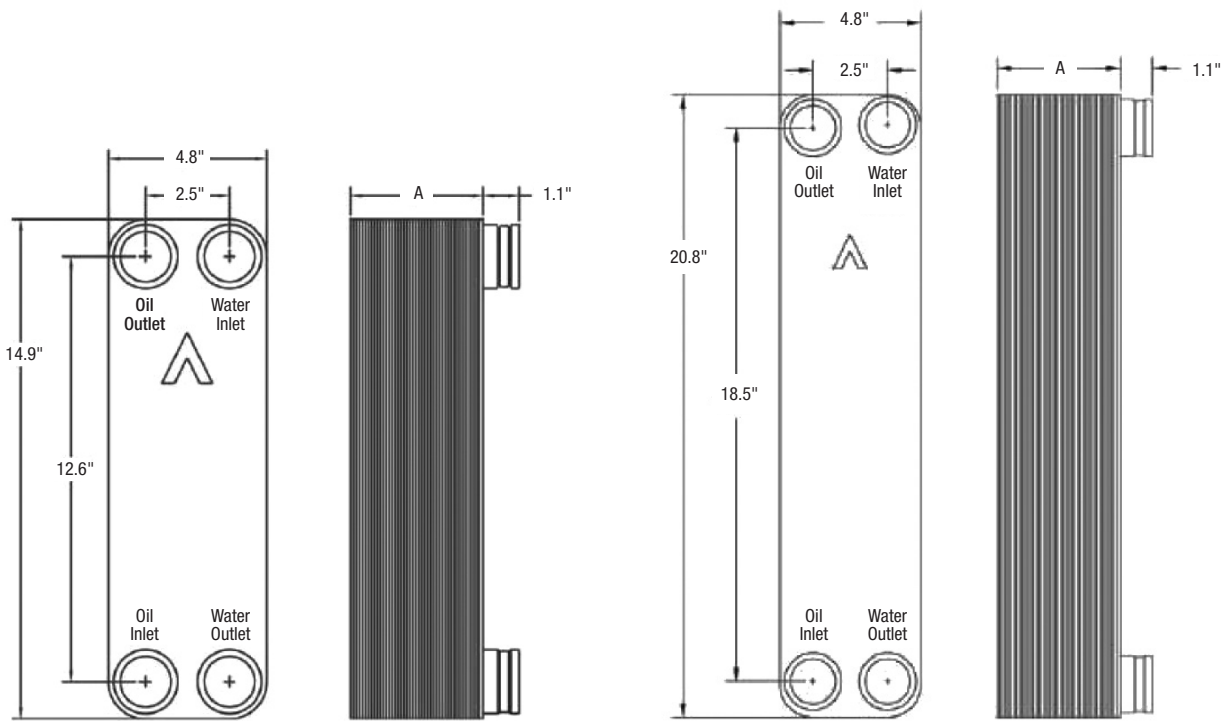
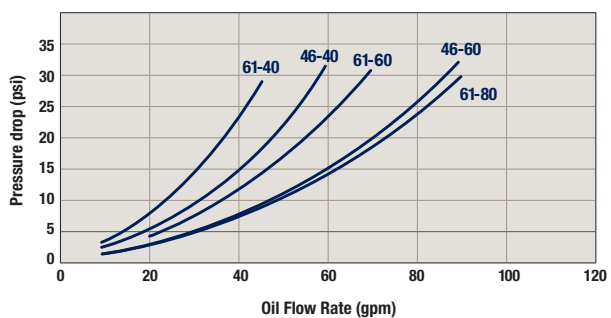

OAW 95 & OAW 126

MODEL	Cooling Capacity (*hp)	Connection	A (inches)	Weight (lbs.)	Volume (in ³)
OAW 95-40	50-150	1½" SAE O-ring	4.1	44	427
OAW 95-60	63-171	1½" SAE O-ring	6.0	59	641
OAW 126-60	84-259	1½" SAE O-ring	6.1	79	856
OAW 126-80	138-274	1½" SAE O-ring	7.9	97	1142

*Cooling capacity is calculated with the following conditions. For other flow conditions, type of fluids or temperatures, please see page 35 or consult Accumulator and Cooler Division. Oil type – ISO VG 32 – Oil/water flow ratio – 2:1 – Oil inlet temperature – 140°F – Water inlet temperature – 80°F

OAW 95 & 126 COOLING CAPACITY

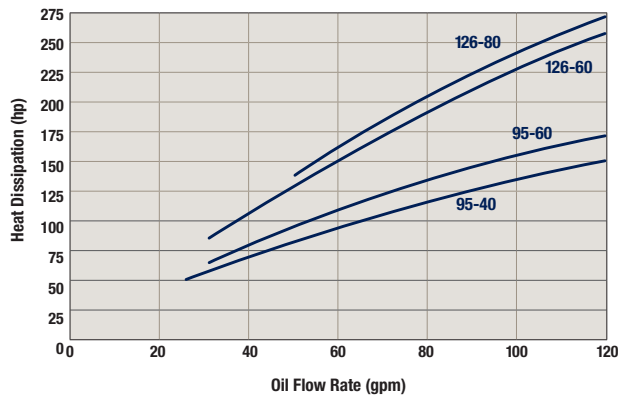

OAW 95 & 126 PRESSURE DROP

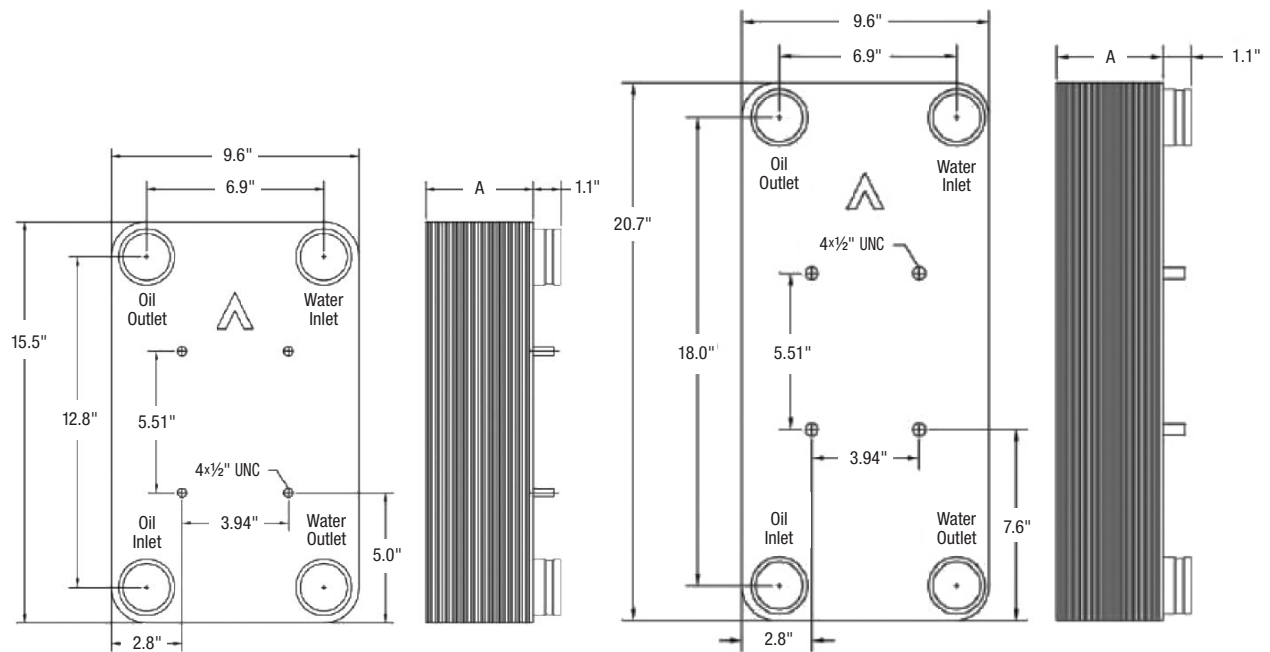
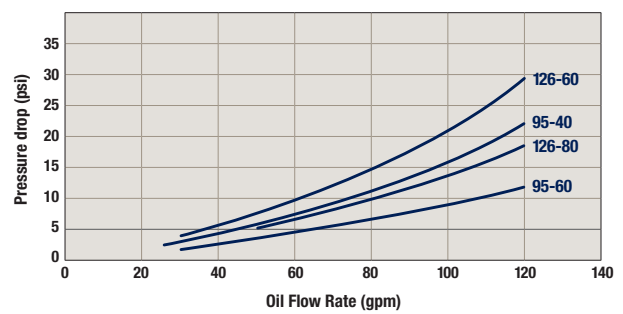

Installation

Installation Instructions for OAW Coolers

The OAW coolers are designed for a maximum working pressure of 450 psi. The most standard application for the OAW cooler involves a cold water circuit and a hot oil circuit. Fluids are not limited to oil and water however; for other types of fluid, please contact the factory.

Inlets and outlets are clearly identified by the Accumulator and Cooler Division sticker affixed to the front of the unit. When in doubt, pour a liquid in one of the connections and note which connection it comes out of. This will be the inlet and outlet for one circuit (either oil or water). The other inlet should be located on the diagonal from the first inlet.

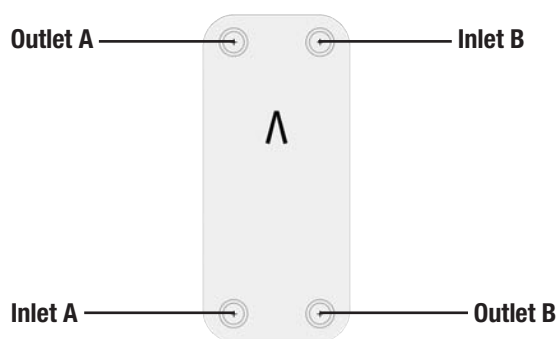

Maximum cooling efficiency is achieved by cross flowing through the plates, the oil inlet and water inlet being located on a diagonal. Failure to have the cooler attached in this manner will lead to a decrease in efficiency.

The cooler may be mounted in any position. However, requirements for draining the circuits should be taken into consideration.

The OAW coolers must not be installed into a rigid frame. Use the Accumulator and Cooler Division purpose-made brackets (or "Armaflex" equivalent) to provide a "soft, elastic installation." The OAW 95 and 126 series coolers come equipped with stud bolts to assist in mounting. However, these bolts alone should not be used to suspend the cooler. All tubing should be done in such a way as to minimize vibrations to the cooler. When installed on a return line, the cooler should be connected using flexible hoses.

When to Clean

Fouling occurs mainly on the water side of the cooler. Fouling can be detected by monitoring the inlet and outlet temperatures and/or the pressure drop across the cooler. Fouling will result in decreased heat transfer, producing temperature differences lower than specified.

Fouling also restricts the passages and thus causes an increase in velocity. This will produce an increase in the pressure drop across the cooler. When either the temperature difference or the pressure drop is significantly different from specified values, cleaning should be performed.

Methods of Cleaning

If cleaning the cooler is required, backflushing with water will remove most of the soft deposits. If fouling appears in the form of hard deposits, circulate a weak acid through the cooler in reverse direction to normal water flow. Use 5% phosphoric acid for infrequent cleanings. For more frequent cleaning, use 5% oxalic acid or similar weak organic acid. Afterwards flush with a large quantity of water to remove all acid from the cooler before starting up the system again. Never wait until the cooler is completely clogged before cleaning!

Filters or Strainers

When there are particles in the fluid that could clog the cooler, filters or strainers should be used. Particles up to 1mm diameter will not cause any problems.

Fluid Compatibility

On the oil side, most synthetic and petroleum based fluids may be used. For aggressive oils, please contact Accumulator and Cooler Division for compatibility. On the water side, de-mineralized and untreated water may be used without concern. When water is chemically treated please contact Accumulator and Cooler Division for suitability. Sea water cannot be used in OAW coolers. For sea water applications, please contact Accumulator and Cooler Division on information on titanium coolers. Do not use ammonia in the OAW coolers.

Correction Factors for Other Oil Types, Temperatures and Flow Rates

All of the cooling curves are based on very specific conditions. These include using an ISO VG 32 oil, having an oil/water ratio of 2:1, and having an oil/water inlet difference of 60 °F. For other conditions, the following correction factors should be used.

Correction Factors for Other Oil Types

Cooling Capacity: Multiply the requested cooling capacity with the correction factor Kv.

Oil Pressure Drop: Multiply the pressure drop with the correction factor Kp.

Viscosity Class	Cooling Capacity Factor, Kv	Pressure Drop Factor, Kp
ISO VG 22	0.95	0.9
ISO VG 32	1.0	1.0
ISO VG 46	1.05	1.3
ISO VG 68	1.2	1.7
ISO VG 100	1.35	2.2
ISO VG 150	1.6	3.0
ISO VG 220	1.9	4.3

Table 1

Correction Factors for Other Inlet Temperature Differences

Cooling Capacity: For inlet temperature differences other than 60 °F, multiply the requested cooling capacity by the correction factor Kt.

ETD	30	40	50	60	70
Kt	1.87	1.43	1.17	1.0	0.88

Table 2

Correction Curves for Other Oil/Water Flow Ratios

Cooling Capacity: For all other oil/water flow ratios other than 2:1, divide the requested cooling capacity by the factor Kr obtained from the curves in Graph 3.

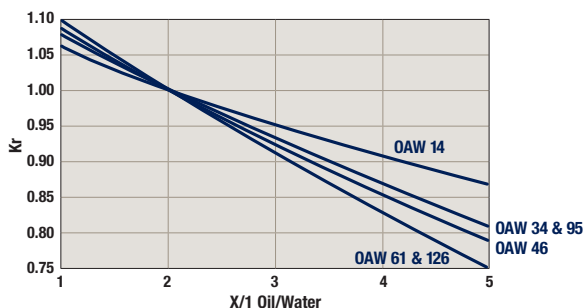

Graph 3

Sizing Example

Conditions:
 Oil type: ISO VG 68
 Oil Flow: 40 gpm
 Desired cooling capacity Qr 40 hp
 Oil temperature in To 140 °F
 Water temperature in Tw 100 °F
 Available water flow 10 gpm
 Maximum Pressure Drop 30 psi

$$ETD = To - Tw = 140^{\circ}F - 100^{\circ}F = 40^{\circ}F$$

The design cooling capacity (Qd) is the cooling capacity used when selecting a suitable cooler. Qd is calculated by multiplying Qr by the factors Kv and Kt (found in Tables 1 and 2 respectively) and then dividing by the Kr factor found from Graph 3.

$$Qd = \frac{Qr \times Kv \times Kt}{Kr} = \frac{40 \text{ hp} \times 1.2 \times 1.43}{0.82} = 83 \text{ hp}$$

According to the cooling capacity curves on page 32, the minimum size cooler for these conditions is an OAW 61-40.

The oil pressure drop can be found from the pressure drop curve. It should be multiplied by the Pressure Drop Factor, Kp from Table 1.

$$D_{Poil} = p \times Kp = 23 \text{ psi} \times 1.7 = 39.1 \text{ psi.}$$

In this case the pressure drop exceeds the maximum allowable. The next size cooler would be an: OAW 61-60

The pressure drop for this cooler would be:

$$D_{Poil} = p \times Kp = 12 \text{ psi} \times 1.7 = 20.4 \text{ psi.}$$

Therefore the correct size cooler would be the OAW 61-60.

For assistance with calculations, please contact Accumulator and Cooler Division.