

General Description

Pilot Operated Spool-Type Relief Valve. For additional information see Technical Tips on pages PC3-PC7.

Features

- Hardened, precision ground parts for durability
- Low profile adapter for minimal space requirements
- Fully guided poppet for more consistent reseal
- Internal screening protects pilot seat from debris
- Steel adapters are zinc plated

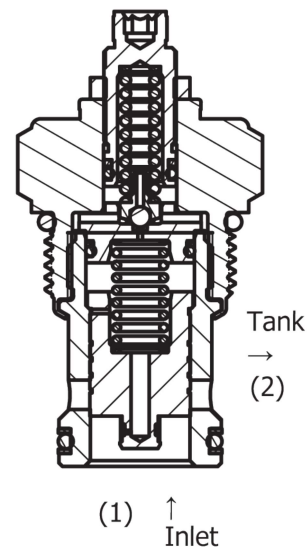
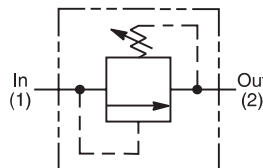

Specifications

Rated Flow	302.8 LPM (80 GPM)
Maximum Inlet Pressure	380 Bar (5500 PSI)
Maximum Pressure Setting	350 Bar (5000 PSI)
Sensitivity: Pressure/Turn	10 19.6 Bar (285 PSI) 20 39.3 Bar (570 PSI) 30 58.9 Bar (859 PSI) 50 131.7 Bar (1910 PSI)
Maximum Tank Pressure	350 Bar (5000 PSI)
Reseat Pressure	90% of crack pressure
Leakage at 150 SSU (32 cSt)	5 cc per 6.8 Bar (100 PSI) setting
Cartridge Material	All parts steel. All operating parts hardened steel.
Operating Temp. Range/Seals	-34°C to +121°C (Nitrile) (-30°F to +250°F) -26°C to +204°C (Fluorocarbon) (-15°F to +400°F)
Fluid Compatibility/Viscosity	Mineral-based or synthetic with lubricating properties at viscosities of 45 to 2000 SSU (6 to 420 cSt)
Filtration	ISO-4406 18/16/13, SAE Class 4
Approx. Weight	0.34 kg (0.75 lbs.)
Cavity	C16-2 (See BC Section for more details)

Performance Curve

Flow vs. Inlet Pressure

(Pressure rise through cartridge only)

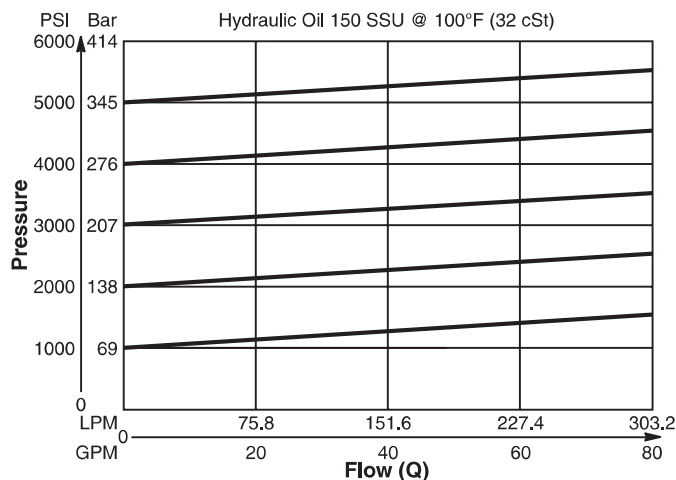

Performance Curve

Regulated Pressure vs. Flow

(Pressure rise through cartridge only)

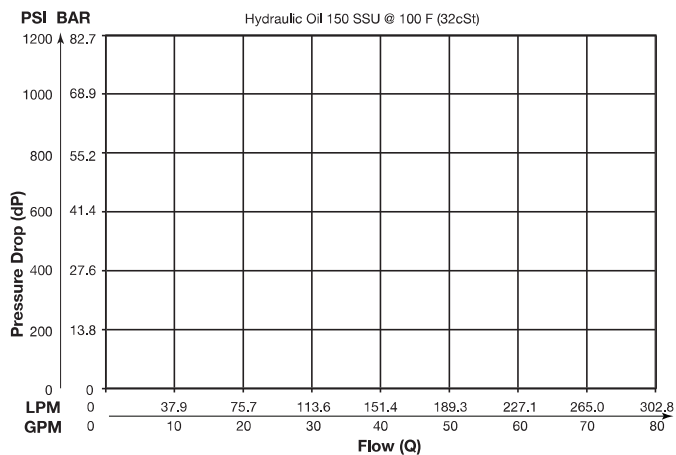

- CV Check Valves
- SH Shuttle Valves
- LM Load/Motor Controls
- FC Flow Controls
- PC Pressure Controls
- LE Logic Elements
- DC Directional Controls
- SV Solenoid Valves
- PV Proportional Valves
- CE Coils & Electronics
- BC Bodies & Cavities
- TD Technical Data

Dimensions Millimeters (Inches)

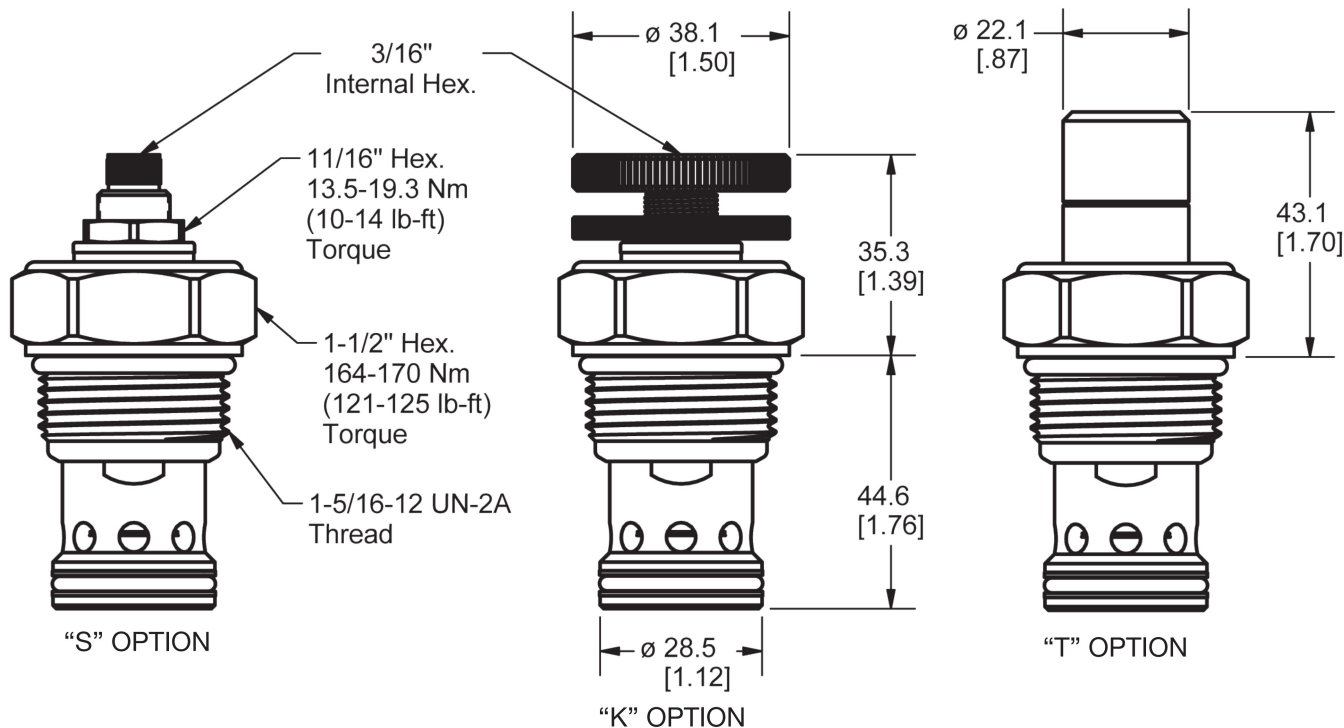

Ordering Information

RAH161	S	
16 Size Pilot Operated Relief Valve	Adjustment Style	Pressure Range

Highlighted represents preferred options that offer the shortest lead times. Other options may be available, but at extended lead times.

Code	Adjustment Style
S	Screw Adjust

Code	Seals
Omit	Nitrile

Order Bodies Separately
 See section BC

B16	2	16T
16 size	2-Way Cavity	Port Size

Code	Porting / Body Material
16T	SAE-16 / Steel (5000 PSI)

Code	Pressure Range
10	6.9 - 69 Bar (100 - 1000 PSI) Standard Setting: 34.5 Bar (500 PSI) @ .95 LPM (25 GPM)
30	20.7 - 207 Bar (300 - 3000 PSI) Standard Setting: 103.5 Bar (1500 PSI) @ .95 LPM (25 GPM)
50	34.5 - 345 Bar (500 - 5000 PSI) Standard Setting: 172.4 Bar (2500 PSI) @ .95 LPM (25 GPM)

Kit	Part Number
Knob	717784-15
Tamper Resistant Cap	717785
Nitrile Seal	SK16-2
Fluorocarbon Seal	SK16-2V

- CV Check Valves
- SH Shuttle Valves
- LM Load/Motor Controls
- FC Flow Controls
- PC Pressure Controls**
- LE Logic Elements
- DC Directional Controls
- SV Solenoid Valves
- PV Proportional Valves
- CE Coils & Electronics
- BC Bodies & Cavities
- TD Technical Data