

Series H Standard Pumps

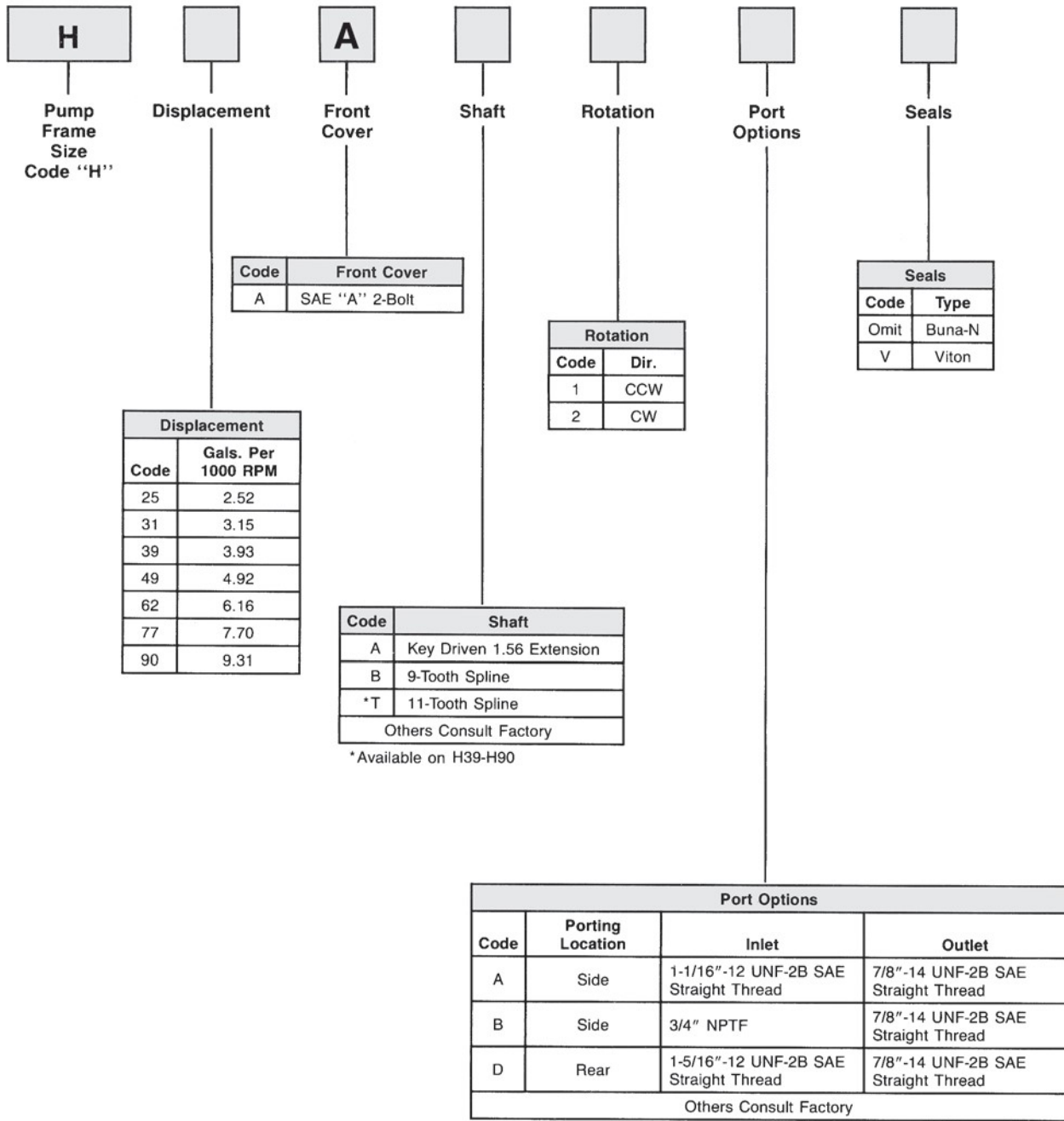

Buna-N Replacement Seal Kit: Order Part No. 706024K
 Viton™ Replacement Seal Kit: Order Part No. 745100K

Series H Standard Pumps

Note: Primarily used on "on-road" power steering pump applications.

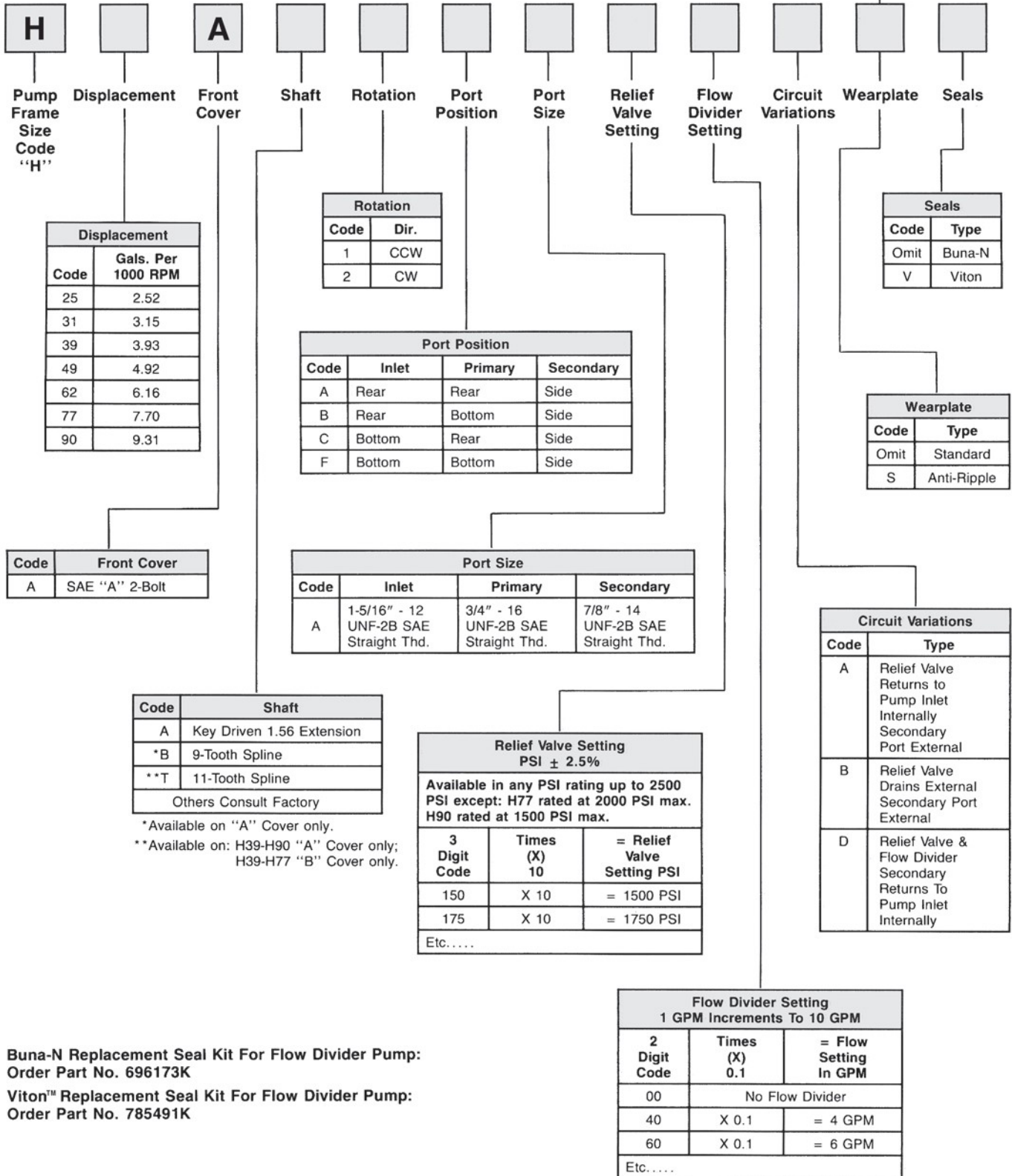

Performance Data

Series H Fixed Displacement, Pressure-Loaded Gear Pump

Features

- Pressure-loaded design
- Efficient, simple design - few moving parts
- Exceptionally compact and lightweight for their capacity
- Efficient at high-pressure operation
- Resistant to cavitation effects
- High tolerance to system contamination
- Reliable under cold weather operation
- Sleeve-bearing construction
- Multi-fluid compatibility

Controls

- Optional built-in relief valve
- Optional built-in relief valve and flow divider
- Special controls (Consult Technical Services)

Specifications

Flow Ratings:

2.5 GPM (9.5 LPM) to 9.3 GPM (35.2 LPM)
(At 1000 RPM) See next page for additional flow data

Pressure Ratings:

H25 thru H62 - 2500 PSI (172 Bar) continuous
H77 - 2000 PSI (138 Bar) continuous
H90 - 1500 PSI (103 Bar) continuous

Speed Ratings:

H25 thru H49 - 500 to 4000 RPM
H62, H77, H90 - 3600 RPM

Mounting:

SAE-A - 2-Bolt Flange
Optional SAE-A - 2-Bolt Flange
Extended Front Cover

Housing Material:

Die-Cast Aluminum

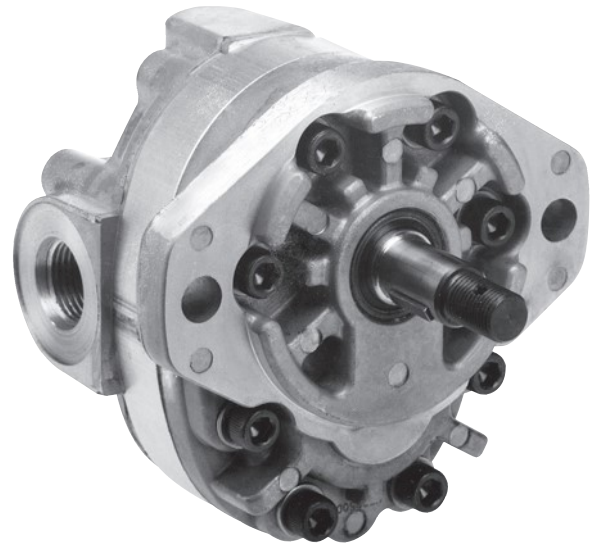

Schematic Symbol

(Basic Pump)



Installation Data

Inlet Conditions:

10 in. hg. max. vacuum condition (at 1800 RPM)
5 in. hg. max. vacuum condition (at max. RPM)
20 PSI (1.4 Bar) max. positive pressure

Operating Temperature Range:

-40°F to 185°F (-40°C to 85°C)

Filtration:

Maintain SAE Class 4

Installation Note:

See page 28 for specific recommendations pertaining to system cleanliness, fluids, start-up, inlet conditions, shaft alignment, and other important factors relative to the proper installation and use of these pumps.

Performance Data

Data Based on 100 SSU
Viscosity Fluids at 120°F (49°C)

Flow In Gallons Per Minute — GPM (LPM)

Pump Model	Displacement IN ³ (CC/REV.)	RPM	100 PSI (6.9 Bar)	1000 PSI (69 Bar)	1500 PSI (103 Bar)	2000 PSI (138 Bar)	2500 PSI (172 Bar)
H25	.603 (9.88)	1200	3.02 (11.45)	2.84 (10.76)	2.75 (10.42)	2.66 (10.08)	2.57 (9.74)
		1800	4.54 (17.21)	4.35 (16.49)	4.26 (16.15)	4.17 (15.80)	4.09 (15.50)
		3600	9.07 (34.38)	8.93 (33.84)	8.85 (33.54)	8.78 (33.28)	8.70 (32.97)
H31	.754 (12.35)	1200	3.78 (14.33)	3.58 (13.57)	3.49 (13.23)	3.40 (12.89)	3.30 (12.50)
		1800	5.67 (21.49)	5.48 (20.77)	5.38 (20.39)	5.28 (20.01)	5.19 (19.67)
		3600	11.34 (42.98)	11.19 (42.41)	11.11 (42.11)	11.03 (41.80)	10.96 (41.54)
H39	.942 (15.44)	1200	4.72 (17.89)	4.51 (17.09)	4.41 (16.71)	4.30 (16.30)	4.20 (15.92)
		1800	7.08 (26.83)	6.87 (26.04)	6.77 (25.66)	6.66 (25.24)	6.56 (24.86)
		3600	14.20 (53.82)	14.00 (53.06)	13.90 (52.68)	13.80 (52.30)	13.70 (51.92)
H49	1.178 (19.30)	1200	5.90 (22.36)	5.67 (21.49)	5.56 (21.07)	5.44 (20.61)	5.33 (20.20)
		1800	8.85 (33.54)	8.62 (32.67)	8.51 (32.25)	8.39 (31.80)	8.28 (31.38)
		3600	17.70 (67.08)	17.50 (66.33)	17.40 (65.95)	17.30 (65.57)	17.20 (65.19)
H62	1.473 (24.14)	1200	7.39 (28.01)	7.13 (27.02)	7.00 (26.53)	6.88 (26.08)	6.75 (25.58)
		1800	11.10 (42.07)	10.81 (40.97)	10.70 (40.55)	10.60 (40.17)	10.40 (39.42)
		3600	22.20 (84.14)	22.00 (83.38)	21.90 (83.00)	21.80 (82.62)	21.70 (82.24)
H77	1.842 (30.18)	1200	9.23 (34.98)	8.95 (33.92)	8.81 (33.39)	8.67 (32.86)	---
		1800	13.90 (52.68)	13.60 (51.54)	13.40 (50.79)	13.30 (50.41)	---
		3600	27.70 (104.98)	27.50 (104.23)	27.40 (103.85)	27.20 (103.09)	---
H90	2.227 (36.50)	1200	11.20 (42.45)	10.90 (41.31)	10.80 (40.93)	---	---
		1800	16.70 (63.29)	16.50 (62.54)	16.30 (61.78)	---	---
		3600	33.50 (126.97)	33.20 (125.83)	33.10 (125.45)	---	---

Performance Data

**Based On Oil Temperature of 120°F (49°C)
 (100 SSU) Atmospheric Inlet**

H25/H31 Horsepower/Speed

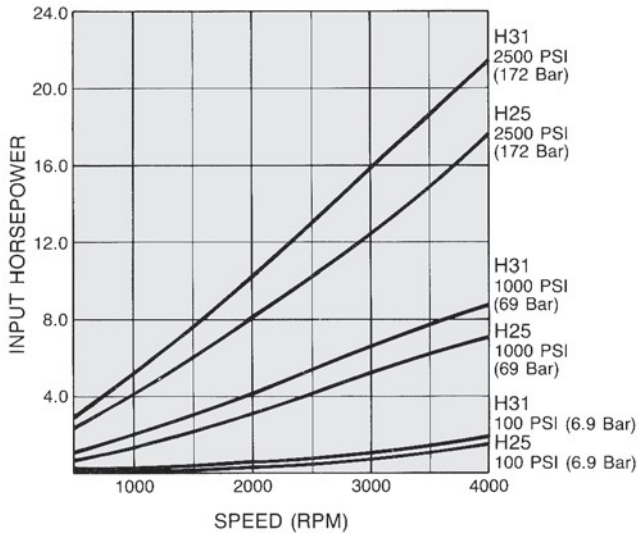

H25/H31 Flow/Speed

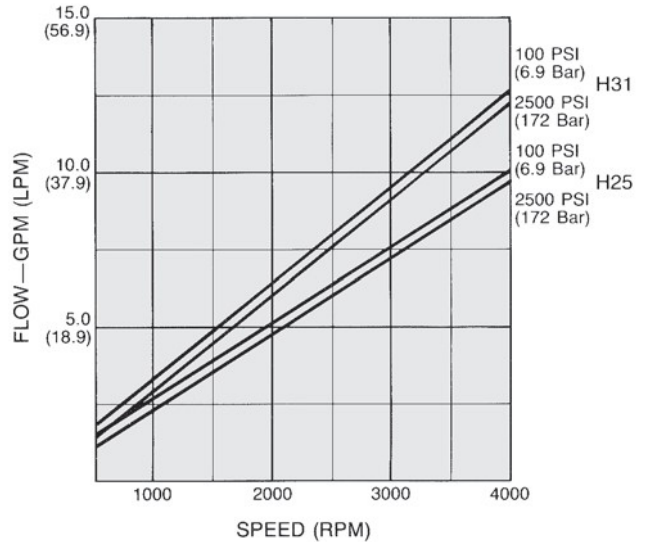

H39/H49 Horsepower/Speed

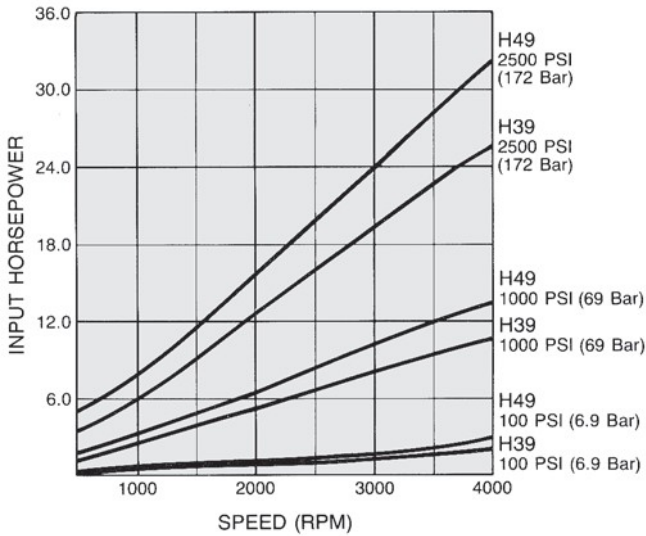

H39/H49 Flow/Speed

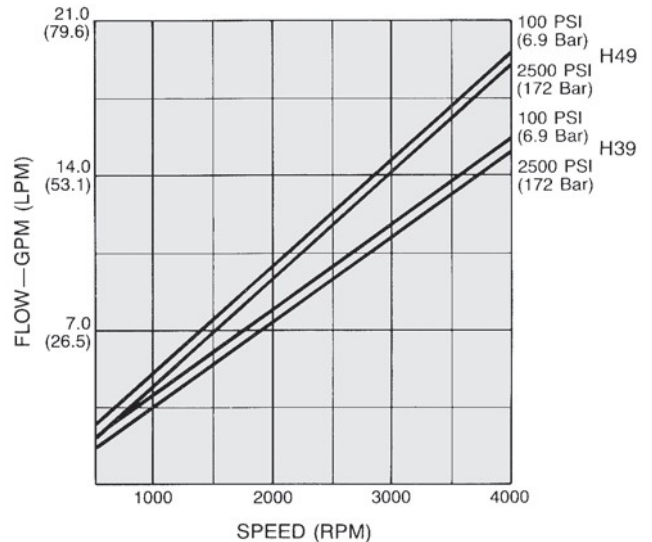

Performance Data

**Based On Oil Temperature of 120°F (49°C)
 (100 SSU) Atmospheric Inlet**

H62/H77 Horsepower/Speed

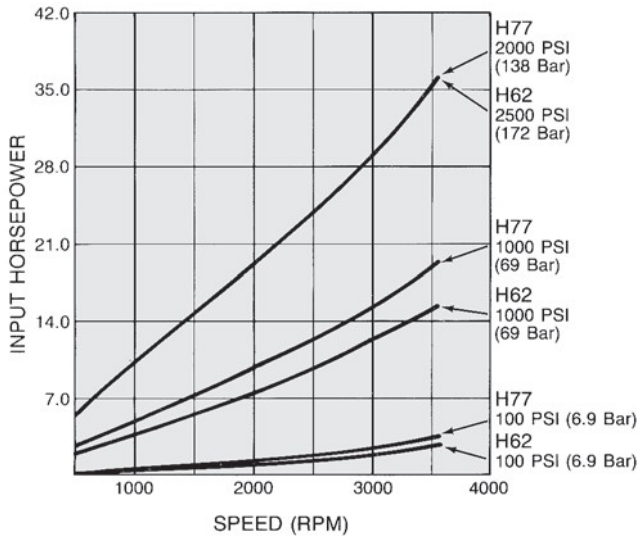

H62/H77 Flow/Speed

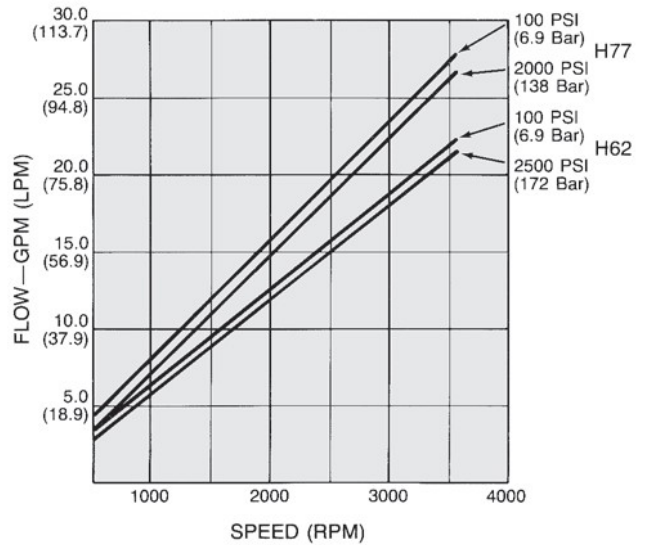

H90 Horsepower/Speed

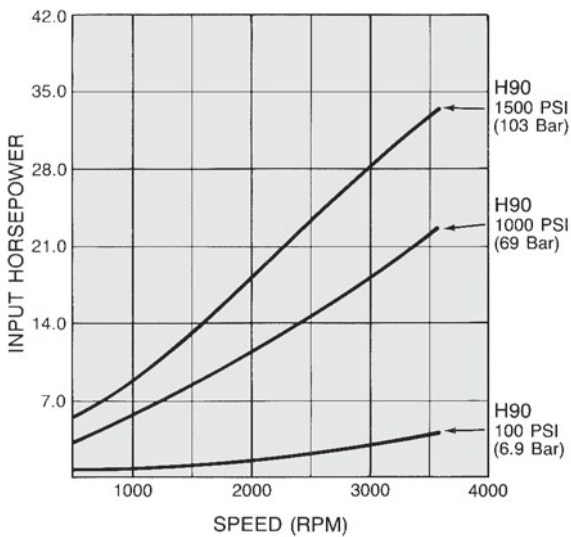

H90 Flow/Speed

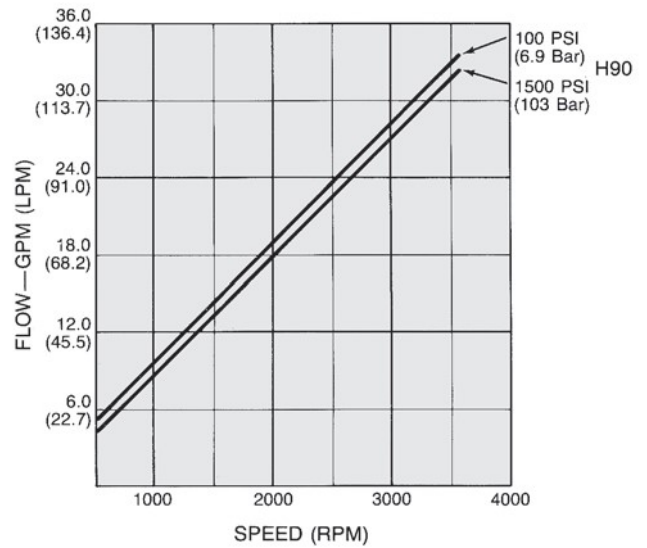

Dimensions – 2-Bolt Mounting

Clockwise rotation and “A” shaft shown
 (Port locations reverse for CCW rotation.)

Dimensions: Inches (mm)

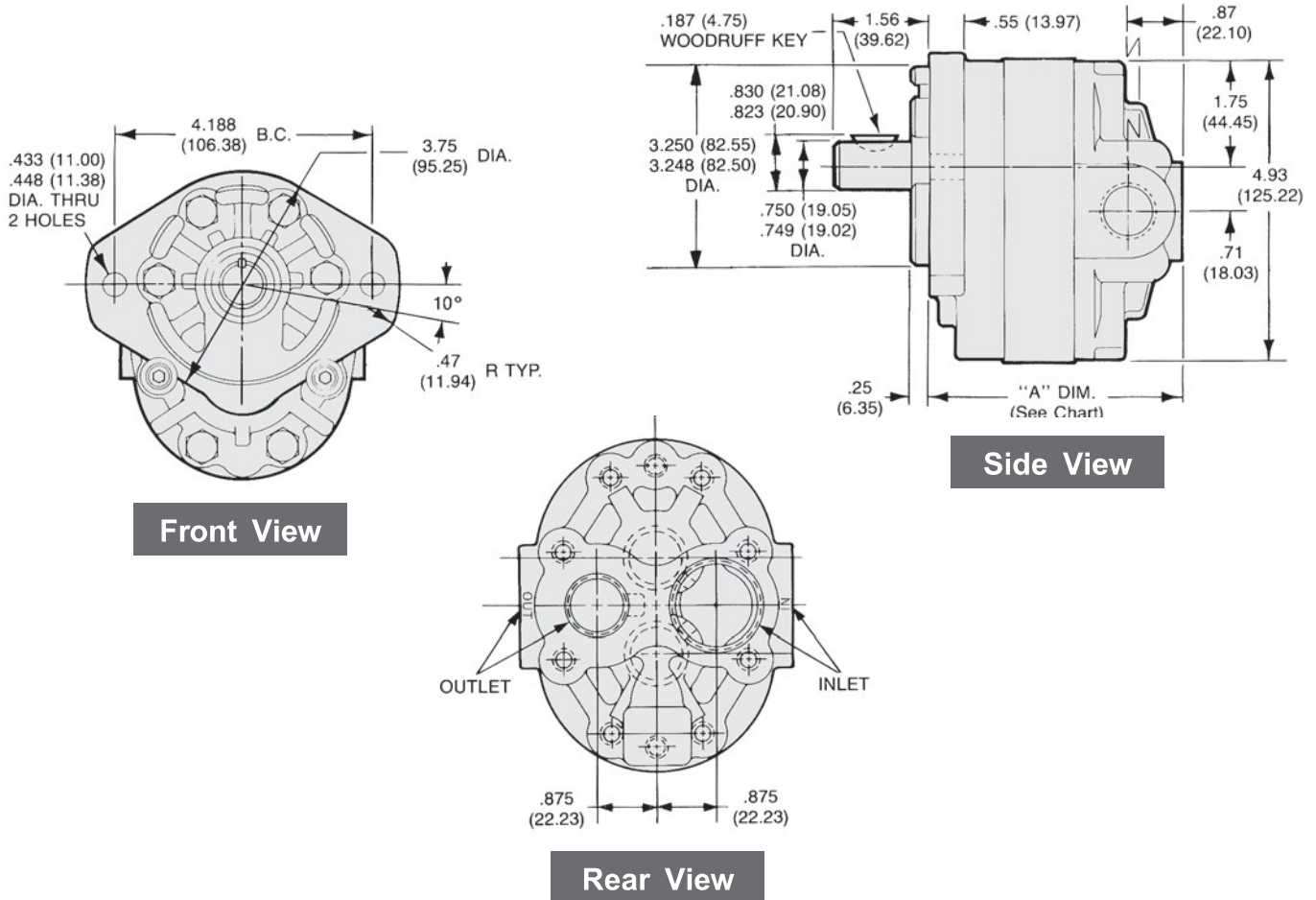

“A” Dimensions: Inches (mm)

Cover	H20	H25	H31	H39	H49	H62	H77	H90
A	3.34 (84.84)	3.43 (87.12)	3.54 (89.92)	3.68 (93.47)	3.86 (98.04)	4.08 (103.63)	4.63 (117.60)	4.92 (124.97)

Cover Option

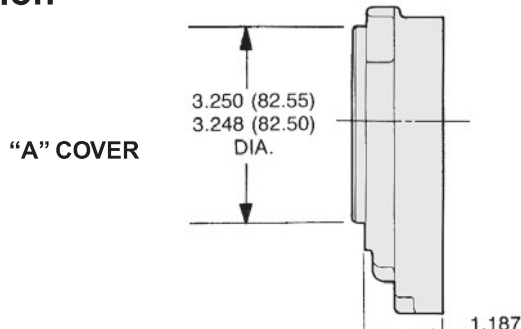

Dimensions – 2-Bolt Mounting

Series with built-in relief valve and flow divider

Dimensions: Inches (mm)

Clockwise rotation and “A” shaft shown
 (Port locations reverse for CCW rotation.)

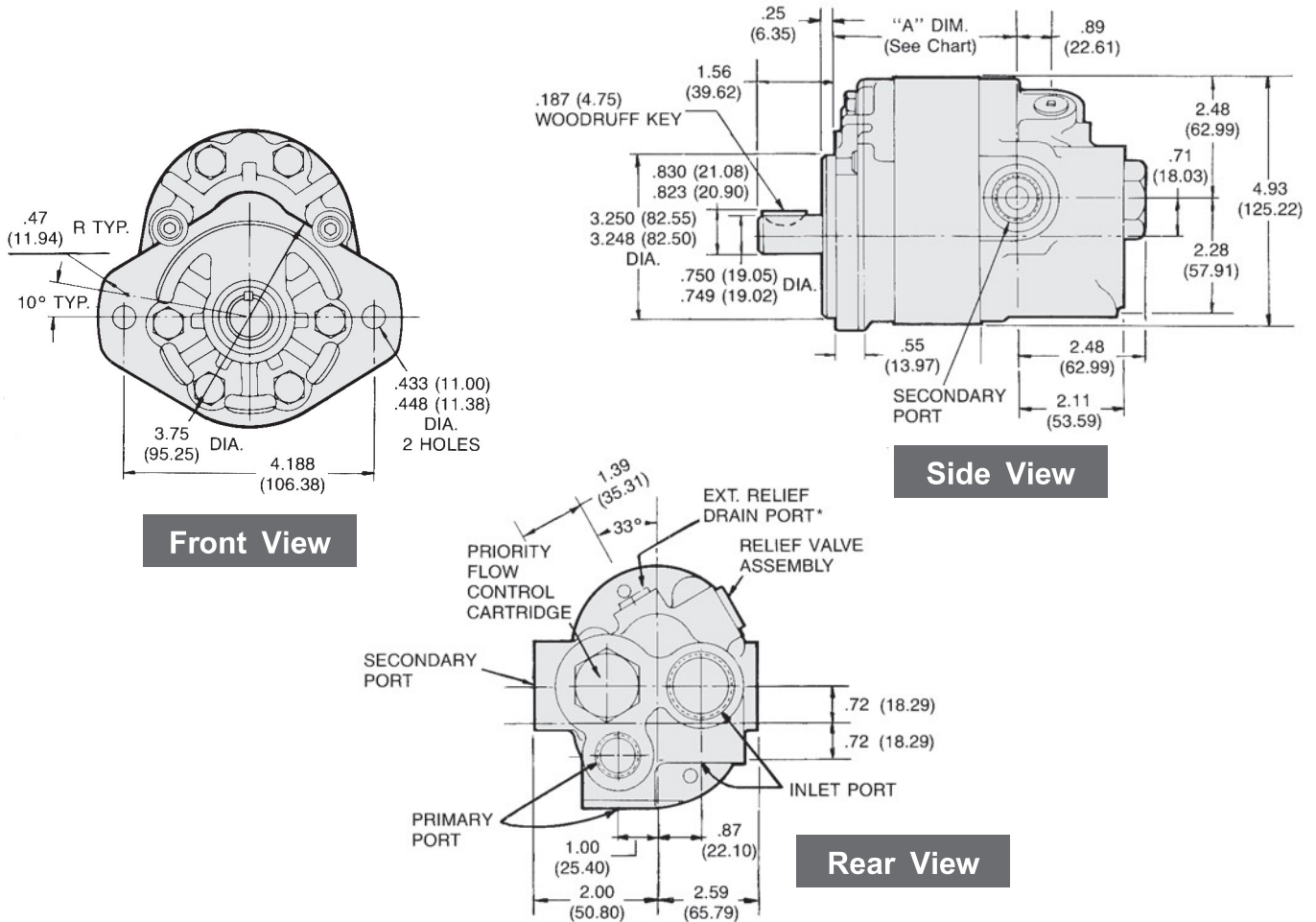

“A” Dimensions: Inches (mm)

Cover	H20	H25	H31	H39	H49	H62	H77	H90
A	2.43 (61.72)	2.52 (64.01)	2.64 (67.06)	2.77 (70.36)	2.95 (74.93)	3.18 (80.77)	3.45 (87.63)	3.75 (95.25)

Circuit Variations

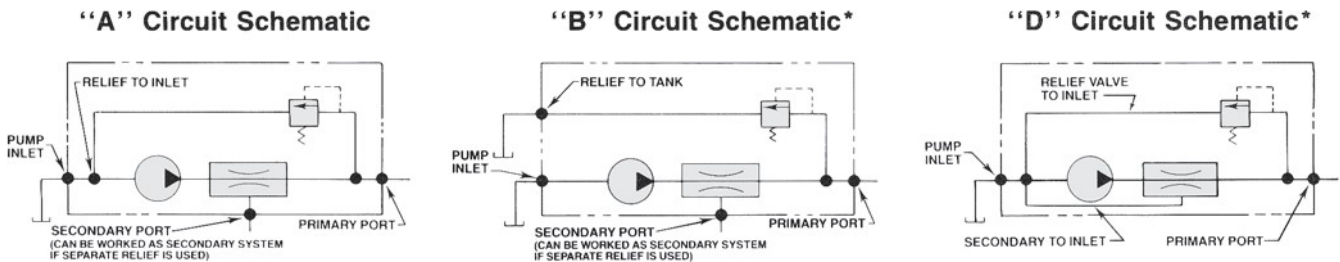

*NOTE: “D” Circuit: Relief valve flow and flow divider secondary flow return to pump inlet internally - primarily used in “on-road” equipment power steering. Relief drain port for “B” variation 9/16”-18 UNF-2B SAE Straight Thread.

Dimensions – Drive Shaft Configurations

Dimensions: Inches (mm)

“T” Shaft

- 3/4” Dia. 11 – tooth spline
- Flat root side fit
- Diametral pitch – 16/32
- Pressure angle – 30°
- No. of teeth – 11

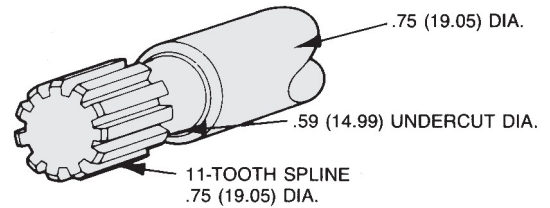
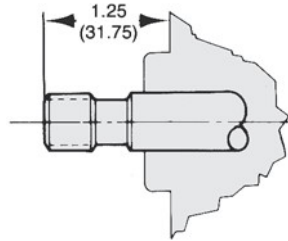

“B” Shaft

- 5/8” dia. 9-tooth spline
- Flat root side fit
- Diametral pitch – 16/32
- Pressure angle – 30°
- No. of teeth – 9

